

AVAILABLE IN STANDARD AND CUSTOM LENGTHS:
 12' - 14000.121
 16' - 14000.161
 20' - 14000.201
 RECEIVER POST OPTION 14000.206

OPTIONAL FINISHES AVAILABLE; PAINTED, GALVANIZED, OR POWER COATED

SPECIFICATIONS ARE SUBJECT TO CHANGE WITHOUT NOTICE. CURRENTLY PRODUCED MODEL MAY DIFFER SLIGHTLY FROM ILLUSTRATIONS.

SURFACE MOUNT



ISOMETRIC VIEW

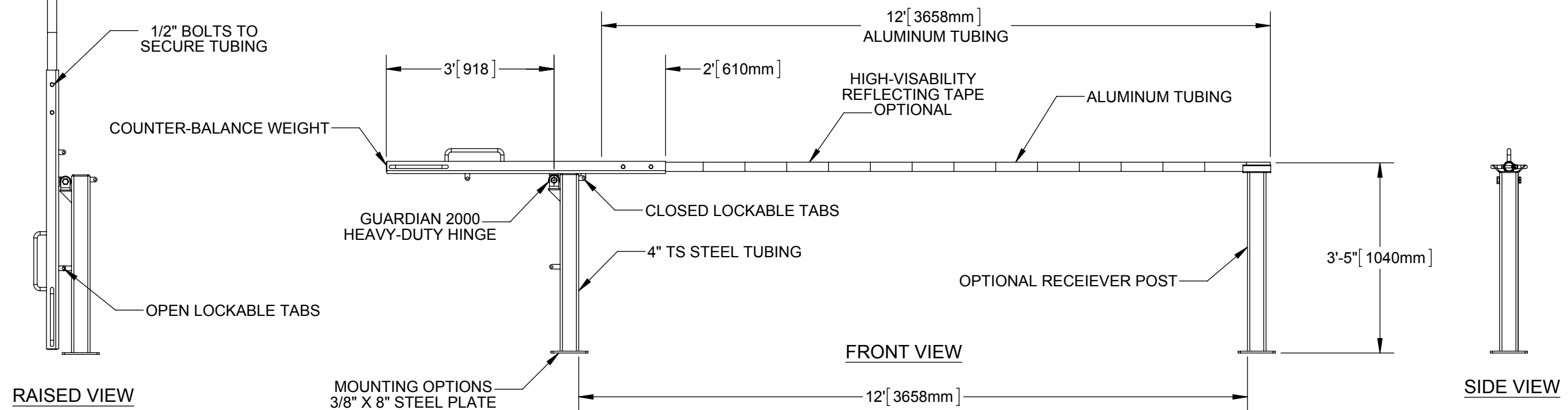

Distributed by Secure Lane
 520-780-9751
www.secure-lane.com
www.barriergatearm.com

© COPYRIGHT © 2013 GUARDIAN TRAFFIC SYSTEMS
 All Rights are included in all the information disclosed herein. This information is submitted in confidence and neither this document nor the information disclosed herein shall be reproduced or transferred to any other person, nor shall it be used or disclosed to any persons for any purpose other than that specifically authorized in writing by Guardian Traffic Systems.

UNLESS OTHERWISE SPECIFIED:
 DIMENSIONS ARE IN INCHES
 TOLERANCES:
 FRACTIONAL: ± 1/8"
 ANGULAR: MACH ± 1° BEND ± R1/6"
 TWO PLACE DECIMAL ± .01
 THREE PLACE DECIMAL ± .005

MATERIAL:		SIZE	PART NUMBER	REV	DESCRIPTION
N/A		B	14000.	-	Manual Lift Barrier Gate Arm
DO NOT SCALE DRAWING	NAME	DATE	WEIGHT: N/A	SHEET 1	
DRAWN	RLS	11/14/13			
SCALE: 1:24					